



©

1962 – 1969 MGB LED Tail Lights Installation Instructions

1. Refer to the parts list at the last page of these instructions and verify that the kit is complete.
Typical install time: Roadster takes about 1 to 1 ½ hours, GT may take some additional time.
2. We suggest that you evaluate the condition of the tail light lens gaskets and if necessary order new ones before starting the installation. The Moss Motors part number:
Pad Lens (2ea.): #164-840
3. Start with the right side tail light assembly. Remove the tail light lens and both bulbs. Open the trunk and disconnect the tail light wiring from the wire harness. Next remove the rubber covers holding the tail light wires. Pull all of the wires out the front of the tail light housing. A small amount of WD-40 will help get the rubber covers over the wire ends. Save these units in case you ever want to restore the tail lights to original condition.
Note: *There can be a problem with the original bullet connectors crumbling when pulled apart. You can buy them from Moss Motors or other British parts suppliers.*
4. Replace the double connector for the red parking light wires with the supplied triple connector. The double connector will be used on the left tail light setup.
5. The new LED tail light grounds are wired directly to the tail light frame mounting lugs. This will also be done on the left side tail light installation. Refer to the installation wiring diagram (Fig.1).
6. Pull the red backing off of the double sided tape on the back of the small circuit board. Take the wires of the circuit board and feed them through the top bulb holder. Pull the wires so that the board is against the bulb reflector. The double sided tape will hold the board against the frame. Apply a bead of Silicon along the top of the circuit board.
7. Take the bottom circuit board and insert it into the tail light lens. Refer to the picture and drawing of Fig 2 for the proper board position. Apply a spot of Silicon rubber at each corner of the circuit board to hold it in the lens. Allow the Silicon to dry before installing the lens.



©

8. Push the bottom circuit board wiring through the bottom bulb holder. Assemble the tail light lens and mount it to the tail light frame.
9. Remove a nut from the back of the tail light frame and attached the ground wire lugs to the stud and reinstall the nut. Make sure that there is a good ground connection at the frame.
Note: Positive ground cars will have two yellow wires for the ground. Negative ground cars will have black ground wires.
10. Repeat the above process for the left side tail light assembly and follow the wiring diagram.
11. When the tail light lenses are assembled then connect the LED wiring to the car's wire harness as defined in the electrical diagram below (Fig 1).
12. The new LED units do not draw enough electrical current to enable the stock turn signal flasher to work correctly. It will light the turn signal but it will not blink. If you have the original turn signal flasher unit you will have to replace it with an electronic one available at any auto parts store. We have been using the Buss-232 flasher unit with good results. Any two connector electronic flasher should work.

1962 – 1969 MGB Tail Light Wiring

*Replace double connector with supplied triple connector.
 Move double connector to left side brake.*

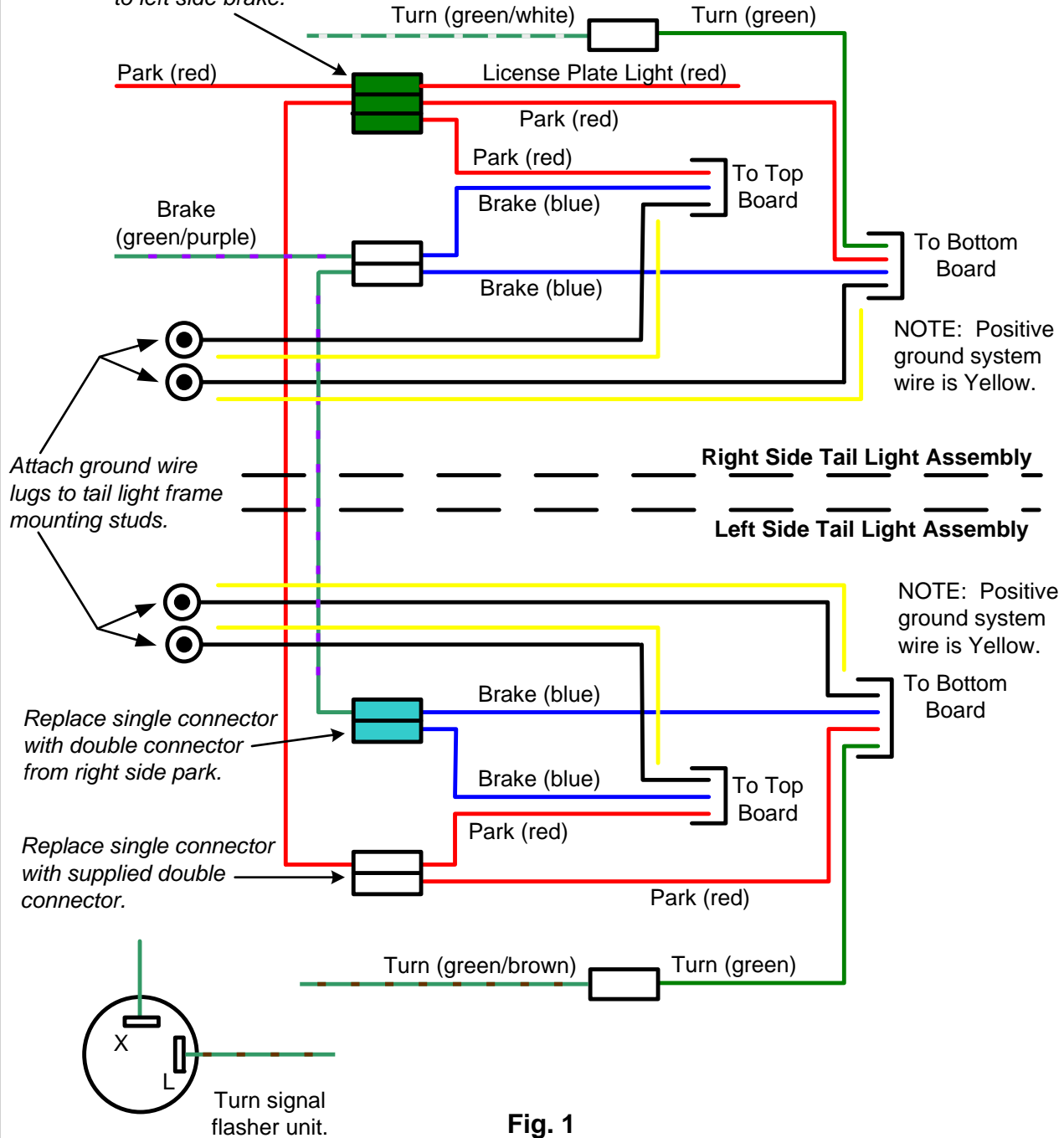
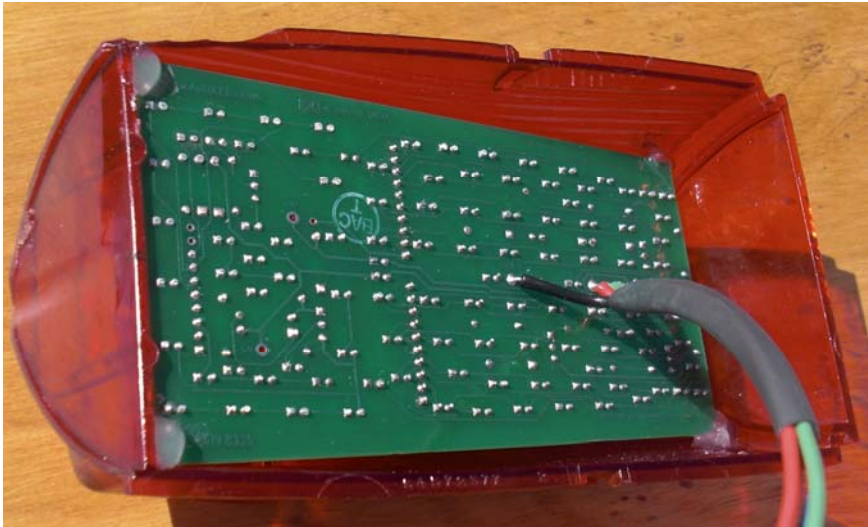
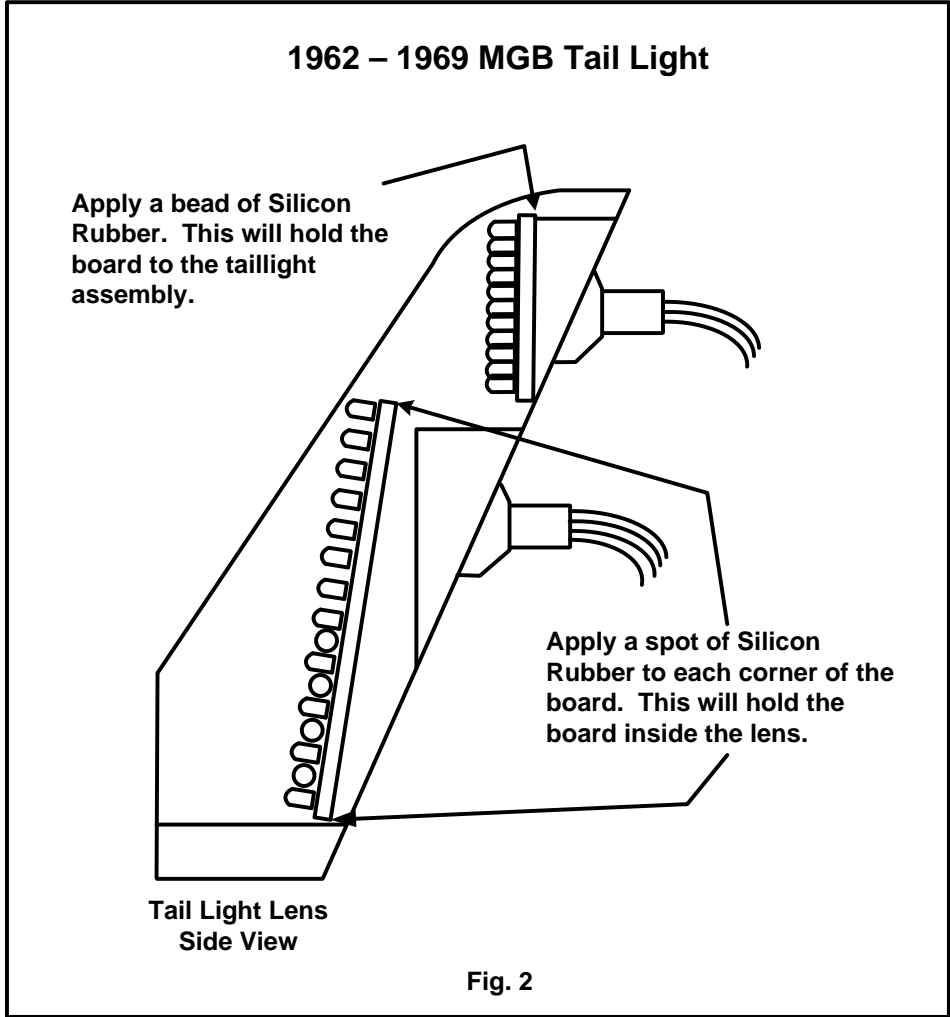

Fig. 1



Kit Contents

Description		Qty
1	Triple bullet wiring connector	1
2	Double bullet wiring connector	1
3	Top brake and parking light circuit board	2
4	Bottom brake, parking light, and turn signal circuit board	2
5	Installation instruction and wiring diagram	1

