



541.619.8335

Designed and Manufactured by:

www.classicautoleds.com

Austin Healey BN1 – BJ7, Jag XK120, MG TD/TF Lucas Lamps: L488/L594 LED Tail Lights Installation Instructions

- 1) Refer to the parts list at the last page of these instructions and verify that the set is complete.

Note: These sets come in either positive (yellow ground wire) or negative (black ground wire) ground configuration. Check that you have the correct set before starting the installation.

Note: We recommend that the tail light functions be verified to operate correctly before installing the LEDs. If possible measure the voltage levels for the running and brake lights at the tail lights. They should be within a few 10ths of a volt compared to the battery voltage. If not you may have wiring issues that should be addressed.

Note: There is an aftermarket tail light lens that is sized differently on the inside from the original lens. Check that the circuit boards fit inside your lenses. Replace with a lens that fits the LED lights.

- 2) LED tail light turn signals usually require an updated flasher unit to work properly. Negative ground cars can use an electronic or electromechanical flasher. Positive ground cars must use an electromechanical flasher. Here is a list of flasher units that have proven to work correctly.

Electromechanical Flasher:

Tridon EL12	2 pin connectors
Tridon EL13	3 pin connectors

Electronic Flasher:

Bussmann 232	2 pin connectors
Bussmann 233	3 pin connectors

- 3) We suggest that you evaluate the condition of the tail light rubber mounting boots and if necessary order new ones before starting installation.
- 4) Remove the tail light lens and bulb. Remove the 3 screws that mount the bulb holder to the rubber boot. Remove the bulb holder and disconnect the 3 wires.
- 5) These light fit several different cars and can have different mounting methods. This set is supplied with 3 mounting flathead screws and nuts. If you need to use another type of mounting screw make sure they are flathead screws. This is necessary due to clearance issues with the circuit boards and the lenses.
- 6) Take the metal ring and mount that in place of the bulb holder using the 3 supplied screws and nuts or you own flathead mounting screws.

- 7) Now set the insulating fiber washer on top of the metal ring. We suggest that you apply a couple of spots of adhesive to the ring to glue it in place before installing the circuit board.
- 8) The circuit boards have long wires which allow you to wire them for your particular car. You can wire the 3 wires inside or outside the rubber boot using the supplied screw connectors. Cut the wires to the required length for your application.
- 9) We suggest that you install the other LED tail light and test both to assure proper operation. After both LEDs are installed and tested then install the lenses and retainer rings.

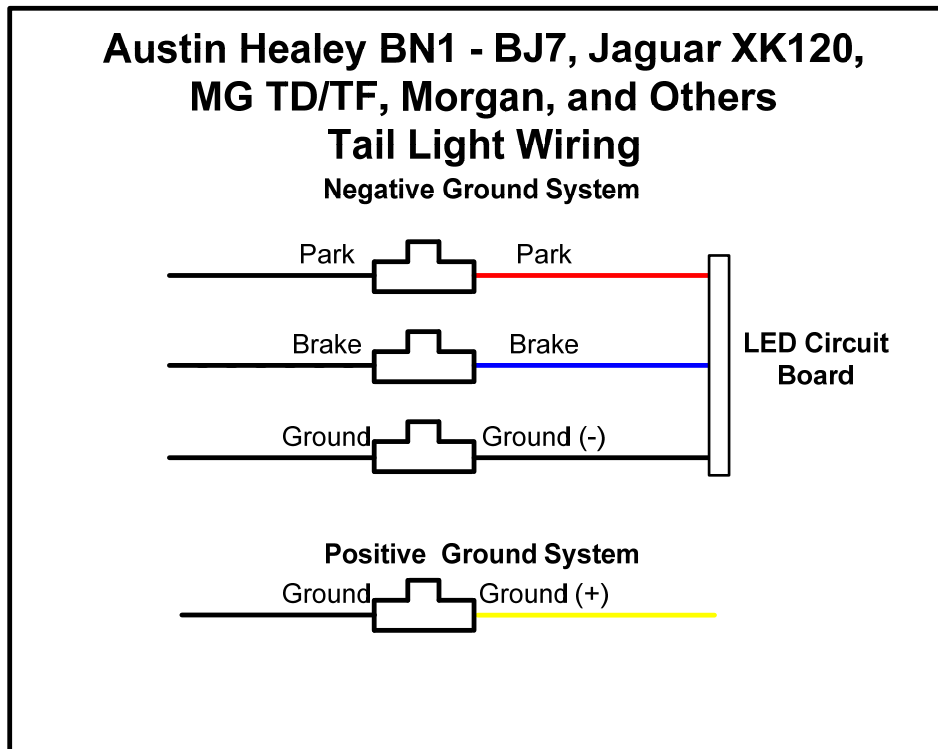

Fig. 1

Parts List



Set Contents
 (Negative Ground Set Shown)

	Description	Qty
1	Insulation Washers	2
2	Steel Mounting Plate	2
3	SS Screw and Nut Sets	6
4	Brake/parking light circuit board	2
5	Installation instruction and wiring diagram	1